







- I
- R
- T
- 1
- 2
- 3
- 4
- 5
- 6
- 7
- 8
- 9
- 10
- 11
- 12
- 13
- 14
- 15
- A

OFFSET STEPPER GEARMOTORS	NEMA Size	Voltage	Gear Ratios	Max. Cont. Torque ozf. in.	Step Angle	Max. Input Speed rpm	Page
	17	35V DC	5:1 10:1 18:1	160	1.8°	1000	14-2
	23			320			14-3

HYBRID STEPPER GEARMOTORS	NEMA Size	Max. Drive Voltage	Min. Holding Torque ozf. in.	Step Angle	Page
	11	24V DC	7 – 15	1.8°	14-7
	17	80V DC	17 – 62.8	.9° & 1.8°	14-9

D.C. GEARMOTORS	Size	Voltage	Rated Torque ozf. in.	No Load Speed rpm	Page
	20	3V DC	.2 – 25	1 – 115	14-11
	20	6V DC	.2 – 25	1 – 115	14-11
		12V DC			

Technical Notes:

- Inertia Conversion Table - pg. 14-4
- Stepper Motor Specifications, Standard Design Features - pg. 14-5
- Hybrid Stepper Motors, NEMA Size 11 - pg. 14-6
- Hybrid Stepper Motors, NEMA Size 17 - pg. 14-8
- Wiring Configuration - pg. 14-10

1.8° NOMINAL MOTOR STEP ANGLE
 5:1, 10:1, 18:1 GEAR RATIOS
 LIGHT-DUTY

PHONE: 516.328.3300 • FAX: 516.326.8827 • WWW.SDP-SI.COM



► MATERIAL:

- Gearhead Housing** - Ryton® (Engineering Resin), Black
- Mounting Flanges** - Ryton® (Engineering Resin), Black
- Output Shaft** - Stainless Steel
- Gears** - Stainless Steel
- Bearings** - Composite Bushings



► OPERATING TEMPERATURE:

-40°F to +255°F

► SPECIFICATIONS:

- Max. Input Speed:** 1000 rpm
- Shaft Loading - Radial:** 4 lbf
- Axial:** 4 lbf
- Shaft Play Max. - Radial:** .002
- Axial:** .010
- Gearhead Max. Cont. Torque:** 160 ozf in.
- Phase Resistance:** 3.3 ohms ± 10% @ 25°C
- Winding Inductance:** 3 mH ± 20%
- Rated Current:** 1.25 Amp. / Phase
- Min. Efficiency:** 80%
- Max. Backlash:** 45 arc min.

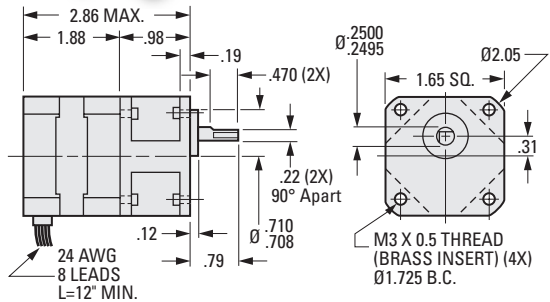

► WEIGHT:

13 oz.

SCHEMATIC

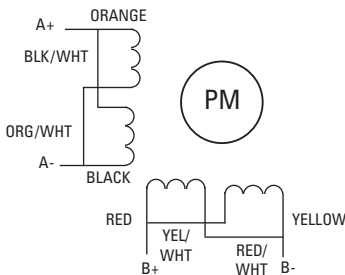

**Bipolar Chopper Drive
 Switching Sequence for CW
 Rotation Facing Mounting End**

Step	A+	A-	B+	B-
0	+	-	+	-
1	-	+	+	-
2	-	+	-	+
3	+	-	-	+
4	+	-	+	-

INCH COMPONENT

Catalog Number	Gear Ratio	Torque Rating ozf in.		Maximum Inertia ozf in. sec. ²
		Cont.	Holding	
S9117C-S18GM005	5:1	See Curve	222	2.67 x 10 ⁻⁵
S9117C-S18GM010	10:1		444	1.82 x 10 ⁻⁶
S9117C-S18GM018	18:1		799	2.97 x 10 ⁻⁴

SPEED vs. TORQUE CHARACTERISTICS
 Drive Setting 35V DC - 1.25 Amps per phase

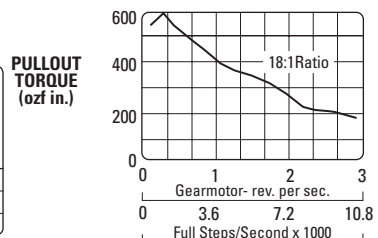
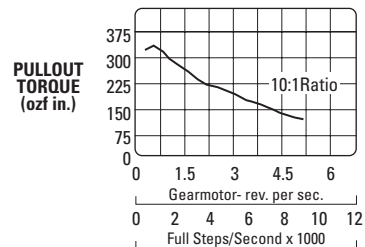
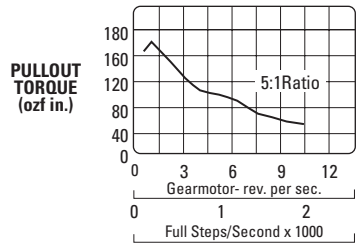

Step Angle is 1.8° per step.

1.8° NOMINAL MOTOR STEP ANGLE
 5:1, 10:1, 18:1 GEAR RATIOS
 LIGHT-DUTY

PHONE: 516.328.3300 • FAX: 516.326.8827 • WWW.SDP-SI.COM



► MATERIAL:

- Gearhead Housing** - Ryton® (Engineering Resin), Black
- Mounting Flanges** - Ryton® (Engineering Resin), Black
- Output Shaft** - Stainless Steel
- Gears** - Stainless Steel
- Bearings** - Composite Bushings

► OPERATING TEMPERATURE:

-40°F to +255°F

► SPECIFICATIONS:

- Max. Input Speed:** 1000 rpm
- Shaft Loading - Radial:** 15 lbf
- Axial:** 15 lbf
- Shaft Play Max. - Radial:** .002
- Axial:** .010
- Gearhead Max. Cont. Torque:** 320 ozf in.
- Phase Resistance:** .37 ohms ± 10% @ 25°C
- Winding Inductance:** .6 mH ± 20%
- Rated Current:** 4.70 Amp. / Phase
- Min. Efficiency:** 80%
- Max. Backlash:** 45 arc min.

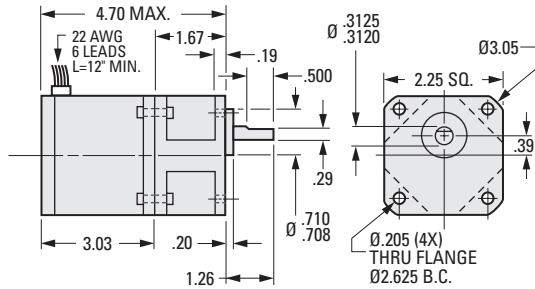
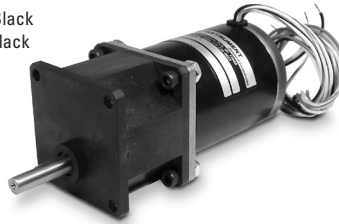

► WEIGHT:

45 oz.

SCHEMATIC

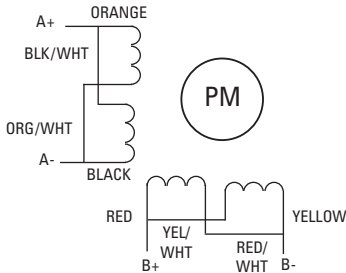

Bipolar Chopper Drive
 Switching Sequence for CW
 Rotation Facing Mounting End

Step	A+	A-	B+	B-
0	+	-	+	-
1	-	+	+	-
2	-	+	-	+
3	+	-	-	+
4	+	-	+	-

INCH COMPONENT

Catalog Number	Gear Ratio	Torque Rating ozf in.		Maximum Inertia ozf in. sec. ²
		Cont.	Holding	
S9123C-S18GM005	5:1	See Curve	500	1.471 x 10 ⁻⁵
S9123C-S18GM010	10:1		1000	9.570 x 10 ⁻⁶
S9123C-S18GM018	18:1		1800	1.986 x 10 ⁻⁵

Step Angle is 1.8° per step.

SPEED vs. TORQUE CHARACTERISTICS
 Drive Setting 35V DC - 3.3 Amps per phase

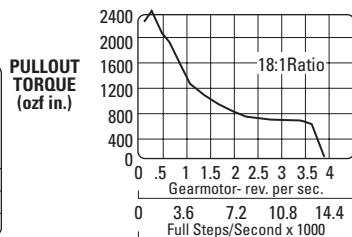
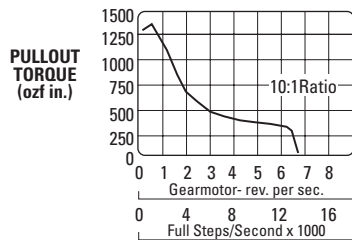
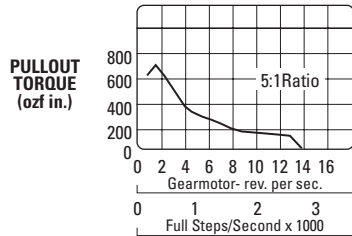



INERTIA CONVERSION TABLE

A \ B	lb _m ft. ²	lbf ft. s ² or slug-ft. ²	lb _m in. ²	lbf in. s ²	oz _m in. ²	ozf in. s ²	kg cm. ²	kgf cm. s ²	g cm. ²	gfc m. s ²
lb _m ft. ²	1	3.108 x 10 ⁻²	144	.373	2.304 x 10 ³	5.968	421.40	0.4297	4.214 x 10 ⁵	429.71
lbf ft. s ²	32.174	1	4.633 x 10 ³	12	7.413 x 10 ⁴	192	1.356 x 10 ⁴	13.825	1.356 x 10 ⁷	1.383 x 10 ⁴
lb _m in. ²	6.944 x 10 ⁻³	2.158 x 10 ⁻⁴	1	2.590 x 10 ⁻³	16	4.144 x 10 ⁻²	2.926	2.984 x 10 ⁻³	2.926 x 10 ³	2.984
lbf in. s ²	2.681	8.333 x 10 ⁻²	386.1	1	6.177 x 10 ³	16	1.130 x 10 ³	1.152	1.130 x 10 ⁶	1.152 x 10 ³
oz _m in. ²	4.34 x 10 ⁻⁴	1.349 x 10 ⁻⁵	6.25 x 10 ⁻²	1.619 x 10 ⁻⁴	1	2.59 x 10 ⁻³	0.183	1.865 x 10 ⁻⁴	182.901	0.186
ozf in. s ²	0.168	5.208 x 10 ⁻³	24.13	6.25 x 10 ⁻²	386.088	1	70.616	7.201 x 10 ⁻²	7.0616 x 10 ⁴	72.008
kg cm. ²	2.373 x 10 ⁻³	7.376 x 10 ⁻⁵	0.3417	8.851 x 10 ⁻⁴	5.467	1.416 x 10 ⁻²	1	1.0197 x 10 ⁻³	1000	1.0197
kgf cm. s ²	2.327	7.233 x 10 ⁻²	335.109	0.8679	5.362 x 10 ³	13.887	980.665	1	9.807 x 10 ⁵	1000
g cm. ²	2.373 x 10 ⁻⁶	7.376 x 10 ⁻⁸	3.417 x 10 ⁻⁴	8.851 x 10 ⁻⁷	5.467 x 10 ⁻³	1.416 x 10 ⁻⁵	10 ⁻³	1.0197 x 10 ⁻⁶	1	1.0197 x 10 ⁻³
gfc m. s ²	2.327 x 10 ⁻³	7.233 x 10 ⁻⁵	0.3351	8.680 x 10 ⁻⁴	5.362	1.389 x 10 ⁻²	.9807	10 ⁻³	980.667	1

NOTE: To convert from A to B multiply by entry in table.

Example: Convert a rotor inertia of 90 g cm.² to ozf in. sec²
 The multiplier from the table above is 1.416 x 10⁻⁵
 The new inertia = 90 x 1.416 x 10⁻⁵ = 1.27 x 10³ ozf in. sec²



Mechanical, Electrical and Environmental Specifications

SIZE 11	SIZE 14	SIZE 17	SIZE HT17	SIZE 23	SIZE HT23	SIZE 34	SIZE HT34	SIZE 42
Shaft Run-Out mm (inches)								
0.025 (.001)	0.013 (.0005)	0.013 (.0005)	0.013 (.0005)	0.025 (.001)	0.051 (.002)	0.051 (.002)	0.051 (.002)	0.051 (.002)
Radial Play mm / N (inch / lbf)								
0.025 max. @ 4.89 N (.001 max. @ 1.1 lbf)	0.01 max. @ 4.45 N (.0004 max. @ 1 lbf)	0.025 max. @ 19.57 N (.001 max. @ 4.4 lbf)	0.02 max. @ 4.45 N (.0008 max. @ 1 lbf)	0.025 max. @ 4.45 N (.001 max. @ 1 lbf)	0.025 max. @ 4.45 N (.001 max. @ 1 lbf)	0.025 max. @ 4.45 N (.001 max. @ 1 lbf)	0.025 max. @ 4.89 N (.001 max. @ 1.1 lbf)	0.025 max. @ 22.24 N (.001 max. @ 5 lbf)
End Play mm / N (inch / lbf)								
0.076 max. @ 9.79 N (.003 max. @ 2.2 lbf)	0.01 max. @ 8.9 N (.0004 max. @ 2 lbf)	0.025 max. @ 29.36 N (.001 max. @ 6.6 lbf)	0.076 max. @ 9.79 N (.003 max. @ 2.2 lbf)	0.025 max. @ 40.03 N (.001 max. @ 9 lbf)	0.076 max. @ 9.79 N (.003 max. @ 2.2 lbf)	0.025 max. @ 66.72 N (.001 max. @ 15 lbf)	0.076 max. @ 9.79 N (.003 max. @ 2.2 lbf)	0.025 max. @ 66.72 N (.001 max. @ 15 lbf)
Perpendicularity mm (inches)								
0.051 (.002)	0.076 (.003)	0.076 (.003)	0.076 (.003)	0.076 (.003)	0.076 (.003)	0.076 (.003)	0.076 (.003)	0.076 (.003)
Concentricity mm (inches)								
0.051 (.002)	0.051 (.002)	0.051 (.002)	0.051 (.002)	0.051 (.002)	0.076 (.003)	0.051 (.002)	0.076 (.003)	0.076 (.003)
Operating Temperature Range								
-20°C to 40°C (-4°F to 104°F)	-20°C to 50°C (-4°F to 122°F)	-20°C to 50°C (-4°F to 122°F)	-20°C to 50°C (-4°F to 122°F)	-20°C to 50°C (-4°F to 122°F)	-20°C to 50°C (-4°F to 122°F)	-20°C to 50°C (-4°F to 122°F)	-70°C to 40°C (-94°F to 104°F)	-10°C to 40°C (14°F to 104°F)
Insulation Class								
130°C (266°F) Class B	130°C (266°F) Class B	130°C (266°F) Class B	130°C (266°F) Class B	130°C (266°F) Class B	130°C (266°F) Class B	130°C (266°F) Class B	130°C (266°F) Class B	130°C (266°F) Class B
Lead Wire Gauge								
26 AWG	26 AWG	26 AWG	26 AWG	26 AWG	22 AWG	18 AWG	22 AWG	—
Max. Radial Load N (lbf)								
4.89 (1.1)	22.24 (5)	22.24 (5)	22.24 (5)	66.72 (15)	66.72 (15)	111.21 (25)	427.03 (96)	111.21 (25)
Max. Thrust Load N (lbf)								
9.79 (2.2)	13.34 (3)	13.34 (3)	13.34 (3)	111.21 (25)	111.21 (25)	222.41 (50)	800.68 (180)	222.41 (50)

DESIGN TIPS:

- Series-connect lead wires for best torque at low speeds.
- Center tap to end or parallel-connect lead wires for best torque at higher speeds.
- Keep motor case temperature below 100°C. This can be achieved by lowering the motor current or limiting the duty cycle.
- Allow sufficient time to accelerate load.
- Size motor with 100% safety factor for required torque and speed.
- Do not disassemble motors. A significant reduction in motor performance will result.
- Do not machine shafts without consulting Sterling Instrument.
- Do not disconnect motor from drive while in operation.
- Do not use holding torque/detent torque of motor as fail-safe brake.

MOTOR INSTALLATION TIPS:

- Mount the motor securely against a surface with good thermal conductivity such as aluminum.
- Properly align the motor with the load using a flexible coupling.
- Protect the motor shaft from excessive thrust, overhung and shock loads.





4 Lead Wire Configuration - Bipolar Drive

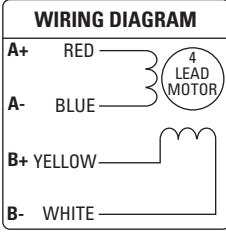

STEP TABLE

STEP	RED	BLUE	YELLOW	WHITE
0	+	-	+	-
1	-	+	+	-
2	-	+	-	+
3	+	-	-	+
4	+	-	+	-

NOTE: If wire configuration is setup step 0-4, shaft will turn cw (facing mounting end).
If setup step 4-0, shaft will turn ccw (facing mounting end).

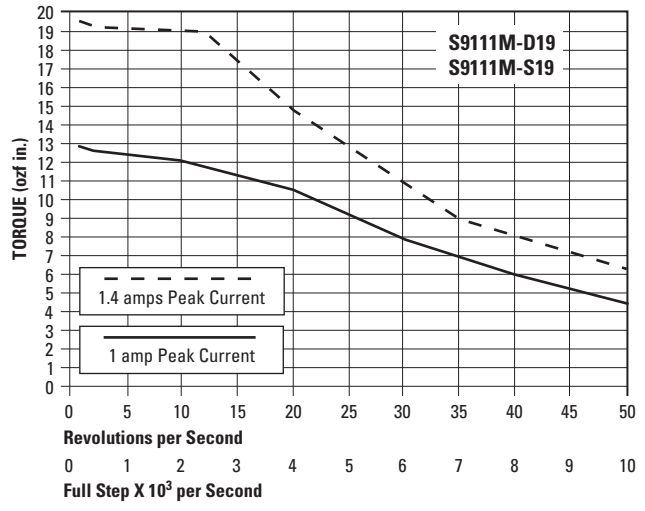
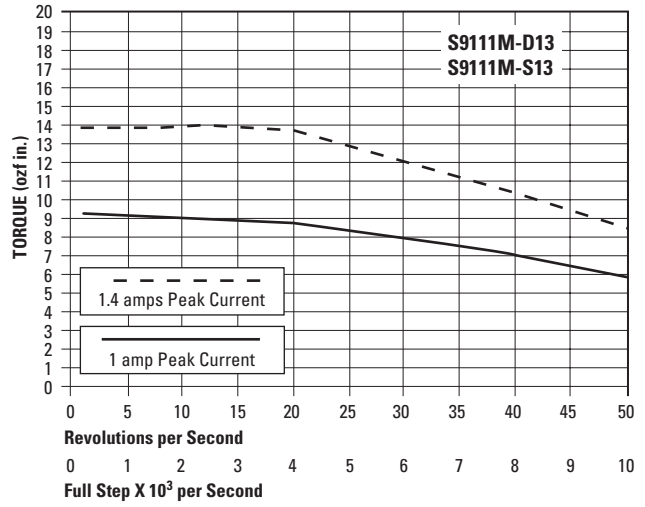

- I
- R
- T
- 1
- 2
- 3
- 4
- 5
- 6
- 7
- 8
- 9
- 10
- 11
- 12
- 13
- 14
- 15
- A

1.8° STEP ANGLE
SINGLE AND DOUBLE-ENDED SHAFTS

PHONE: 516.328.3300 • FAX: 516.326.8827 • WWW.SDP-SI.COM



> **VOLTAGE:**

24V DC Max. Drive

> **SPECIFICATION:**

Leads - 4 (see previous page)
Optimized for microstepping

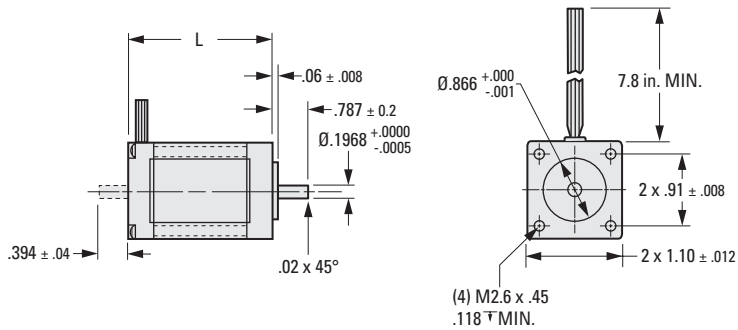
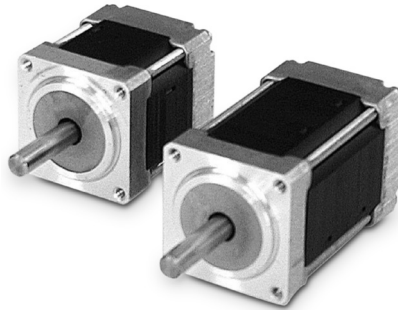

INCH COMPONENT

Catalog Number*	Motor Conn.	L	Min. Holding Torque ozf in.	Phase Current amps	Phase Inductance mH $\pm 20\%$	Phase Resistance ohms $\pm 10\%$	Voltage V DC	Rotor Inertia oz. in. ²	Weight lb.
S9111M-D13	Bipolar	1.32	7.0	1.0	1.4	1.4	1.4	.044	.26
S9111M-S13	Bipolar	1.32	7.0	1.0	1.4	1.4	1.4	.044	.26
S9111M-D19	Bipolar	1.87	15.0	1.0	2.6	2.0	2.0	.098	.39
S9111M-S19	Bipolar	1.87	15.0	1.0	2.6	2.0	2.0	.098	.39

* Catalog Numbers with **D** in the suffix have **double shafts**; **S** in the suffix denotes **single shaft**.

I
R
T
1
2
3
4
5
6
7
8
9
10
11
12
13
14
15
A

MAXIMUM THEORETICAL TORQUE CURVES
DRIVE SETTING 80V DC

PHONE: 516.328.3300 • FAX: 516.326.8827 • WWW.SDP-SI.COM

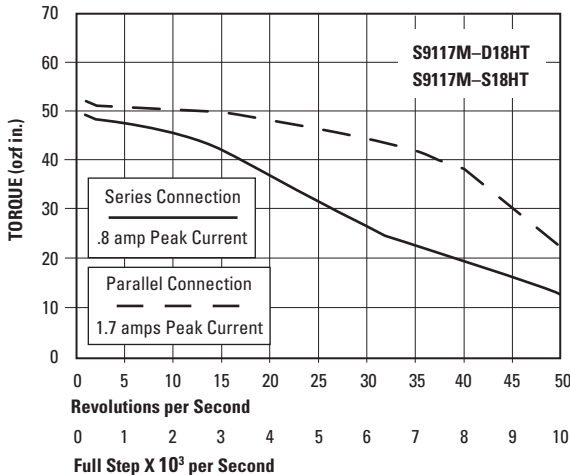
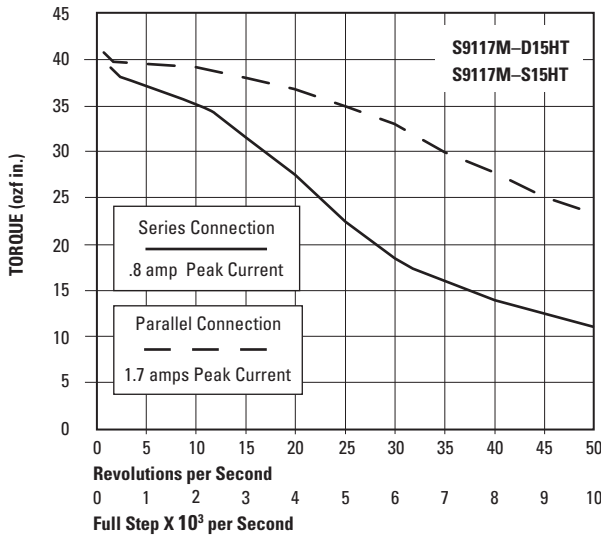
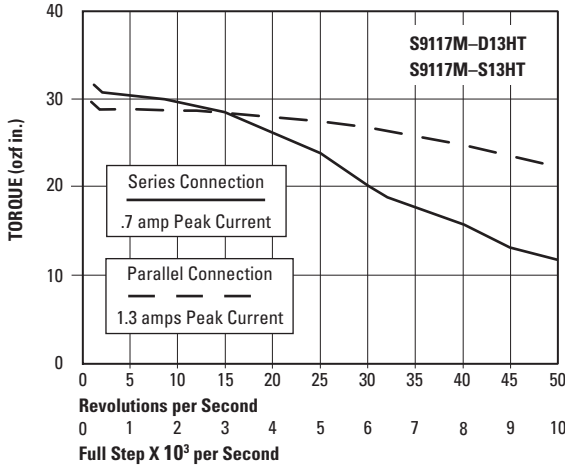

- I
- R
- T
- 1
- 2
- 3
- 4
- 5
- 6
- 7
- 8
- 9
- 10
- 11
- 12
- 13
- 14**
- 15
- 16

1.8° STEP ANGLES
SINGLE- OR DOUBLE-ENDED SHAFTS

PHONE: 516.328.3300 • FAX: 516.326.8827 • WWW.SDP-SI.COM



> **VOLTAGE:**

80V DC Max. Drive

> **SPECIFICATION:**

Leads - 8 (see wiring diagram page)
Optimized for microstepping

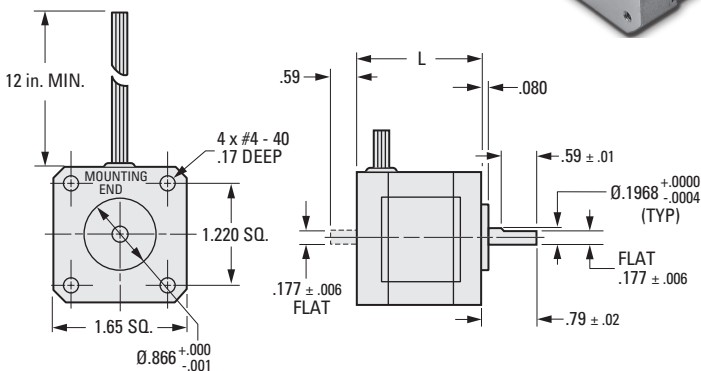
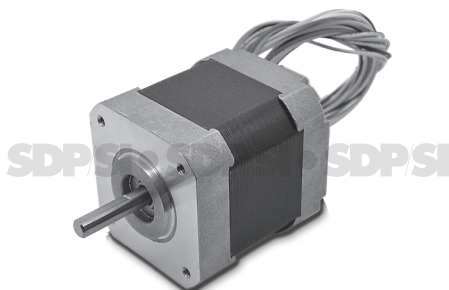

INCH COMPONENT

Catalog Number *	Motor Conn.	L	Min. Holding Torque ozf in.	Step Angle	Phase Current amps	Phase Inductance mH ± 20%	Phase Resistance ohms ± 10%	Voltage V DC	Rotor Inertia oz. in. ²	Weight lb.
S9117M-D13HT S9117M-S13HT	Series	1.30	31.1	1.8	.67	10.0	8.4	5.7	.21	.44
	Parallel		31.1		1.34	2.5	2.1	2.8		
	Unipolar		22.6		.95	2.5	4.2	4.0		
S9117M-D15HT S9117M-S15HT	Series	1.54	51.0	1.8	.85	14.4	6.6	5.7	.29	.57
	Parallel		51.0		1.70	3.6	1.7	2.8		
	Unipolar		36.1		1.20	3.6	3.3	4.0		
S9117M-D18HT S9117M-S18HT	Series	1.85	62.8	1.8	.85	12.0	6.6	5.7	.37	.73
	Parallel		62.8		1.70	3.0	1.7	2.8		
	Unipolar		44.4		1.20	3.0	3.3	4.0		

* Catalog Numbers with **D** in the suffix have **double shafts**; **S** in the suffix denotes **single shaft**.

- I
- R
- T
- 1
- 2
- 3
- 4
- 5
- 6
- 7
- 8
- 9
- 10
- 11
- 12
- 13
- 14
- 15
- 16



**8 Lead Wire Configuration
Unipolar Drive**

STEP TABLE				
Step	Orange	Black	Red	Yellow
0	ON	OFF	ON	OFF
1	OFF	ON	ON	OFF
2	OFF	ON	OFF	ON
3	ON	OFF	OFF	ON
4	ON	OFF	ON	OFF

Connect orange/white, black/white, red/white, and yellow/white to plus (+) voltage.

UNIPOLAR DRIVE ONLY!

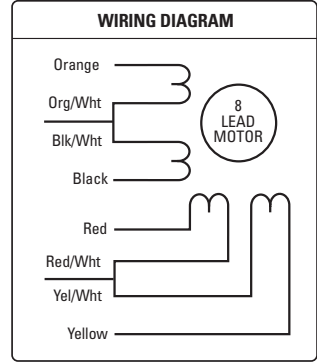

**8 Lead Wire Configuration
Bipolar Drive / Parallel Connected**

STEP TABLE				
Step	A+	A-	B+	B-
0	+	-	+	-
1	-	+	+	-
2	-	+	-	+
3	+	-	-	+
4	+	-	+	-

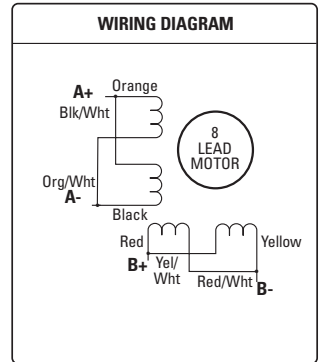

**8 Lead Wire Configuration
Bipolar Drive / Series Connected**

STEP TABLE				
Step	Orange	Black	Red	Yellow
0	+	-	+	-
1	-	+	+	-
2	-	+	-	+
3	+	-	-	+
4	+	-	+	-

Note: If wire configuration is setup step 0–4, shaft will turn cw (facing mounting end). If setup step 4–0, shaft will turn ccw (facing mounting end).

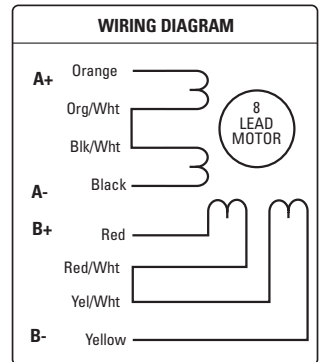

I
R
T
1
2
3
4
5
6
7
8
9
10
11
12
13
14
15
A

D.C. GEARMOTORS



LOW VOLTAGE
REVERSIBLE
SELF-STARTING

PHONE: 516.328.3300 • FAX: 516.326.8827 • WWW.SDP-SI.COM

► **MATERIAL:**

Housing - Molded Plastic
Shaft - Steel

► **SPECIFICATIONS:**

No Load Drain Approx:
10 mA @ 3V
8 mA @ 6V
4 mA @ 12V

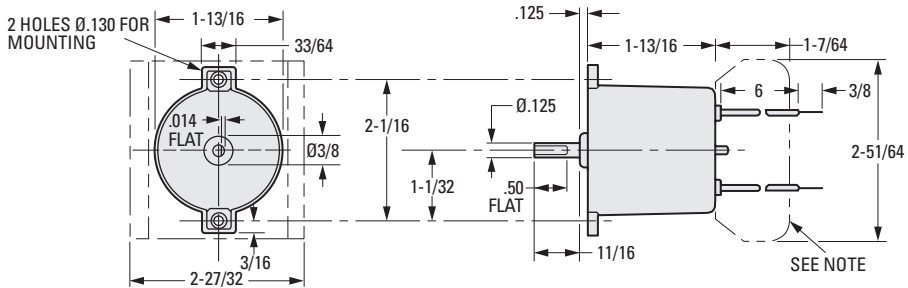
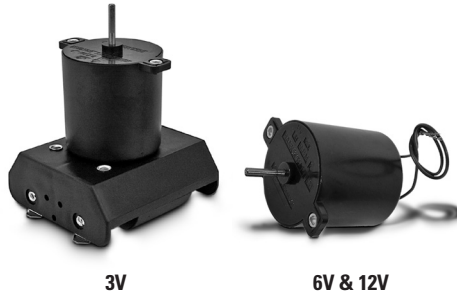

INCH COMPONENT			No Load rpm	Gear Ratio	Stall Torque ozf in.	Rated Torque ozf in.
Catalog Number						
3 Volts	6 Volts	12 Volts				
A 3Z16-0010A	A 3Z16-0010B	A 3Z16-0010C	1.0	1740:1	65.0	25.0
A 3Z16-0015A	A 3Z16-0015B	A 3Z16-0015C	1.5	1075:1	40.0	16.0
A 3Z16-0020A	A 3Z16-0020B	A 3Z16-0020C	2.0	845:1	31.0	12.0
A 3Z16-0040A	A 3Z16-0040B	A 3Z16-0040C	4.0	435:1	18.0	6.0
A 3Z16-0050A	A 3Z16-0050B	A 3Z16-0050C	5.0	342:1	14.0	5.0
A 3Z16-0070A	A 3Z16-0070B	A 3Z16-0070C	7.0	269:1	12.0	4.0
A 3Z16-0085A	A 3Z16-0085B	A 3Z16-0085C	8.5	211:1	10.0	3.0
A 3Z16-0160A	A 3Z16-0160B	A 3Z16-0160C	16.0	109:1	5.0	1.5
A 3Z16-0200A	A 3Z16-0200B	A 3Z16-0200C	20.0	86:1	3.2	1.0
A 3Z16-0250A	A 3Z16-0250B	A 3Z16-0250C	25.0	67:1	2.8	.9
A 3Z16-0300A	A 3Z16-0300B	A 3Z16-0300C	30.0	53:1	2.4	.7
A 3Z16-1150A	A 3Z16-1150B	A 3Z16-1150C	115.0	16:1	.8	.2

NOTE: 3 Volt gearmotors supplied with twist-on clip for two "D" size batteries (not included).